

TECHNICAL CHARACTERISTICS

1. General Characteristics

Dimension: 26.60L x 18.70W x 2.00H mm
 Weight: Approx. 1.23 g
 Contact principle: Friction technology
 Operating position: Shaft up / Down / Horizontal
 Mounting System: SMT Type (post optional)
 Function: Push Push Type
 Durability: 5,000 cycles min.

2. Mechanical Characteristics

Insulation material: Thermoplastic, UL 94V-0
 RoHS Directive 2011/65/EU Compliant

3. Electrical Characteristics

Number of contacts: 6, 8 pins (optional)
 Contact resistance: 50 mΩ typical, 100 mΩ max.
 Insulation resistance: >1000 MΩ / 500 VDC
 Switch type: Blade
 Operation: Normally Close

4. Solderability

Wave: Not applicable
 IR reflow: 260°C, 10 sec. Max.
 Manual soldering: 360°C, 3 sec. Max.

5. Environmental Characteristics

Operating temperature: - 40°C ~ + 85°C
 Operating humidity: 10 % ~ 95 % RH
 Storage temperature: - 40°C ~ + 85°C
 Storage humidity: 10 % ~ 95 % RH

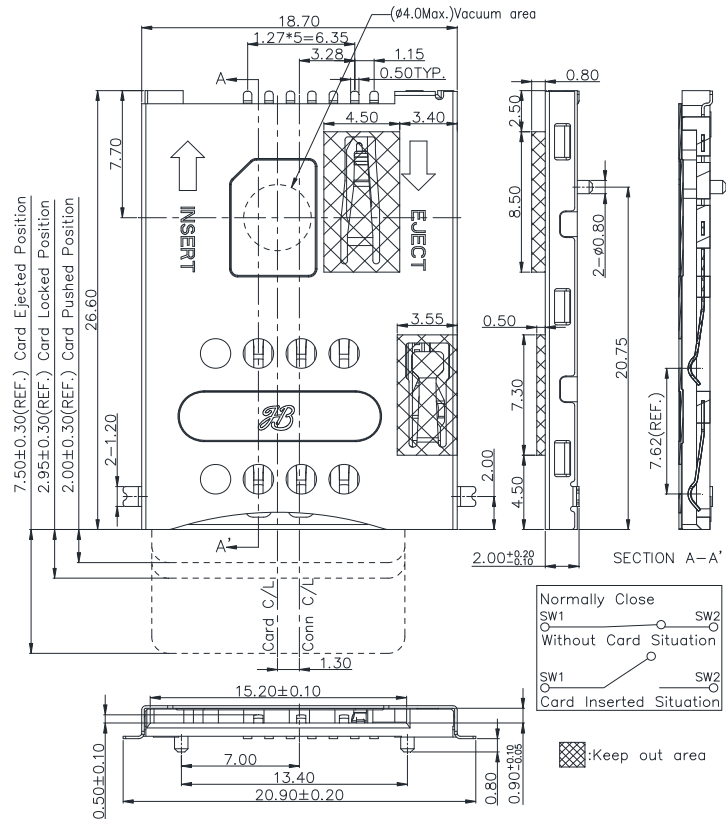

Unit: mm; Tolerances: ±0.15 mm
Mechanical outline dimension

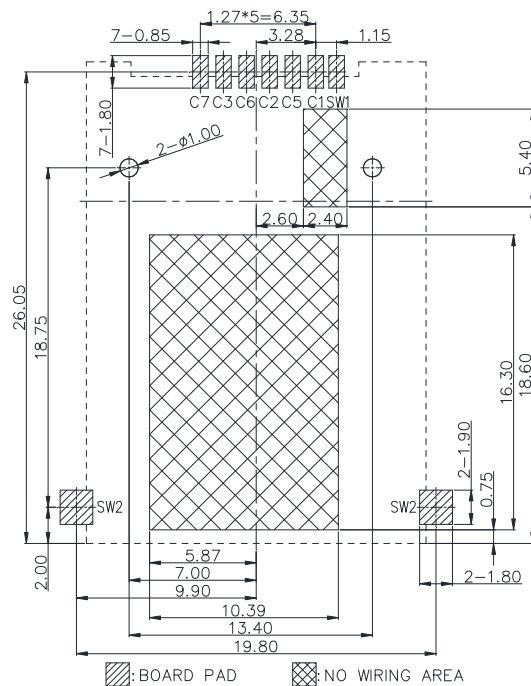

Unit: mm; Tolerances: ±0.05 mm
Reference dimension for PCB layout

Note:

- Coplanarity of solder pins 0.10mm max.
- Recommended thickness of solder paste > 0.15mm.

HB SIM Card Acceptor

Model No.: ICA-561 Type1 6Pin+Post

Revision: 1.4

Date: JAN. 02, 2020

For further information, please contact:

Tel: +886 2 2662 8882(Rep.) Fax: +886 2 2662 7201~2 E-mail: taipei@hamburg.com.tw URL: <http://www.hamburg.com.tw>

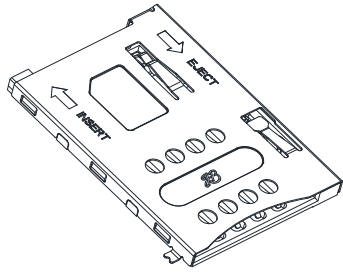

TECHNICAL CHARACTERISTICS

1. General Characteristics

Dimension: 26.60L x 18.70W x 2.00H mm
 Weight: Approx. 1.23 g
 Contact principle: Friction technology
 Operating position: Shaft up / Down / Horizontal
 Mounting System: SMT Type (post optional)
 Function: Push Push Type
 Durability: 5,000 cycles min.

2. Mechanical Characteristics

Insulation material: Thermoplastic, UL 94V-0
 RoHS Directive 2011/65/EU Compliant

3. Electrical Characteristics

Number of contacts: 6, 8 pins (optional)
 Contact resistance: 50 mΩ typical, 100 mΩ max.
 Insulation resistance: >1000 MΩ / 500 VDC
 Switch type: Blade
 Operation: Normally Close

4. Solderability

Wave: Not applicable
 IR reflow: 260°C, 10 sec. Max.
 Manual soldering: 360°C, 3 sec. Max.

5. Environmental Characteristics

Operating temperature: - 40°C ~ + 85°C
 Operating humidity: 10 % ~ 95 % RH
 Storage temperature: - 40°C ~ + 85°C
 Storage humidity: 10 % ~ 95 % RH

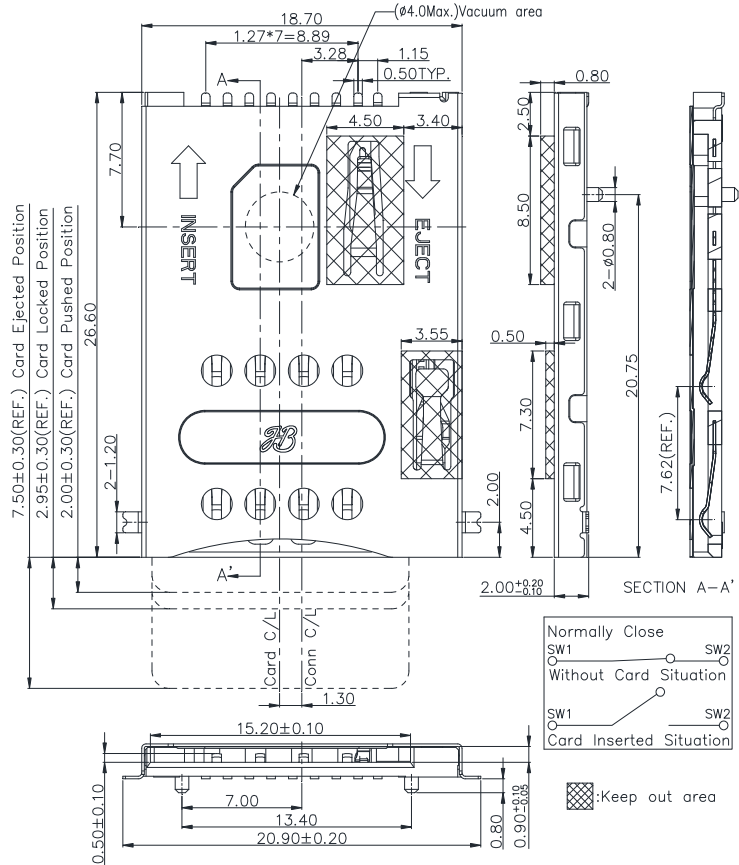

Unit: mm; Tolerances: ±0.15 mm
 Mechanical outline dimension

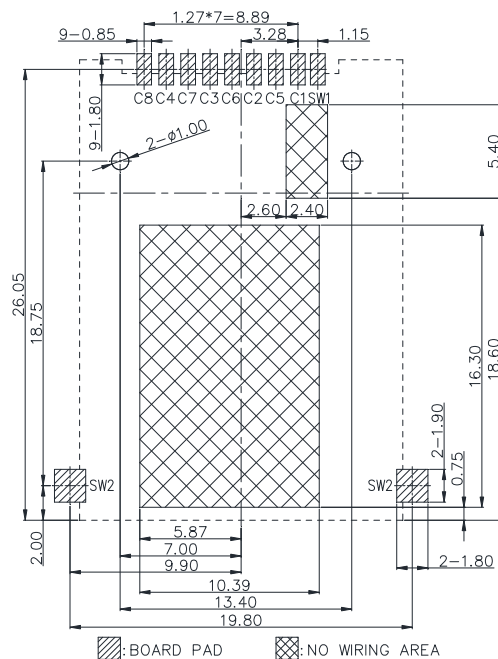

Unit: mm; Tolerances: ±0.05 mm
 Reference dimension for PCB layout

Note:

- Coplanarity of solder pins 0.10mm max.
- Recommended thickness of solder paste > 0.15mm.

HB SIM Card Acceptor

Model No.: ICA-561 Type1 8Pin+Post

Revision: 1.4

Date: JAN. 02, 2020

For further information, please contact:

Tel: +886 2 2662 8882(Rep.) Fax: +886 2 2662 7201-2 E-mail: taipei@hamburg.com.tw URL: <http://www.hamburg.com.tw>