

EMV Compliant

TECHNICAL CHARACTERISTICS

1. General Characteristics

Dimension: 55.50L x 40.00W x 5.80H mm
 Weight: Approx. 11.8 g
 Contact principle: Landing technology
 Operating position: Shaft up / Down / Horizontal
 Mounting System: DIP or SMT Type (with post)
 Durability: 200,000 cycles min.

2. Mechanical Characteristics

Insulation material: Thermoplastic, UL 94V-0
 RoHS Directive 2011/65/EU Compliant

3. Electrical Characteristics

Number of contacts: 8, 16 pins (optional)
 Contact resistance: 50 mΩ typical, 100 mΩ max.
 Insulation resistance: >1000 MΩ / 500 VDC
 Switch type: Sealed
 Operation: Normally Open

4. Solderability

Wave: 260°C, 5 sec. Max.
 IR reflow: Not applicable
 Manual soldering: 360°C, 3 sec. Max.

5. Environmental Characteristics

Operating temperature: - 40°C ~ + 85°C
 Operating humidity: 10 % ~ 95 % RH
 Storage temperature: - 40°C ~ + 85°C
 Storage humidity: 10 % ~ 95 % RH

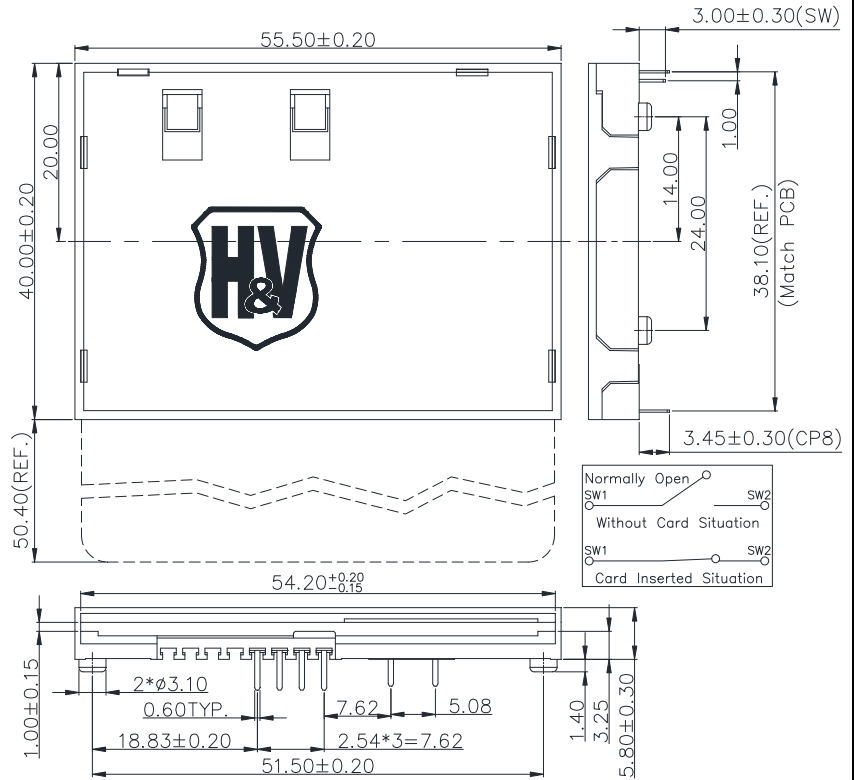

Unit: mm; Tolerances: ±0.15 mm
Mechanical outline dimension

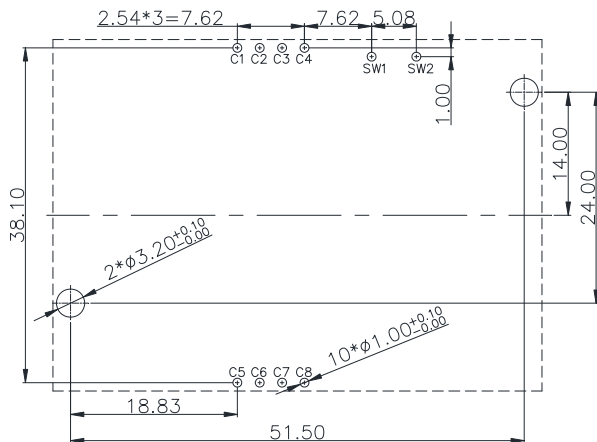

Unit: mm; Tolerances: ±0.05 mm
Reference dimension for PCB layout

H&V Smart Card Acceptor

Model No.: ICA-700 Type1 DIP 8Pin

Revision: 2.2

Date: MAY 01, 2014

For further information, please contact:

Tel: +886 2 2662 8882(Rep.) Fax: +886 2 2662 7201~2 E-mail: taipei@hamburg.com.tw URL: <http://www.hamburg.com.tw>

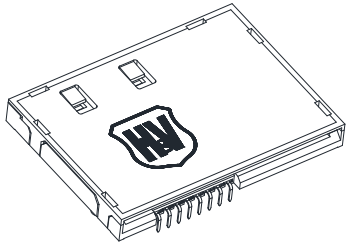

EMV Compliant

TECHNICAL CHARACTERISTICS

1. General Characteristics

Dimension: 55.50L x 40.00W x 5.80H mm
 Weight: Approx. 11.8 g
 Contact principle: Landing technology
 Operating position: Shaft up / Down / Horizontal
 Mounting System: DIP or SMT Type (with post)
 Durability: 200,000 cycles min.

2. Mechanical Characteristics

Insulation material: Thermoplastic, UL 94V-0
 RoHS Directive 2011/65/EU Compliant

3. Electrical Characteristics

Number of contacts: 8, 16 pins (optional)
 Contact resistance: 50 mΩ typical, 100 mΩ max.
 Insulation resistance: >1000 MΩ / 500 VDC
 Switch type: Sealed
 Operation: Normally Open

4. Solderability

Wave: 260°C, 5 sec. Max.
 IR reflow: Not applicable
 Manual soldering: 360°C, 3 sec. Max.

5. Environmental Characteristics

Operating temperature: - 40°C ~ + 85°C
 Operating humidity: 10 % ~ 95 % RH
 Storage temperature: - 40°C ~ + 85°C
 Storage humidity: 10 % ~ 95 % RH

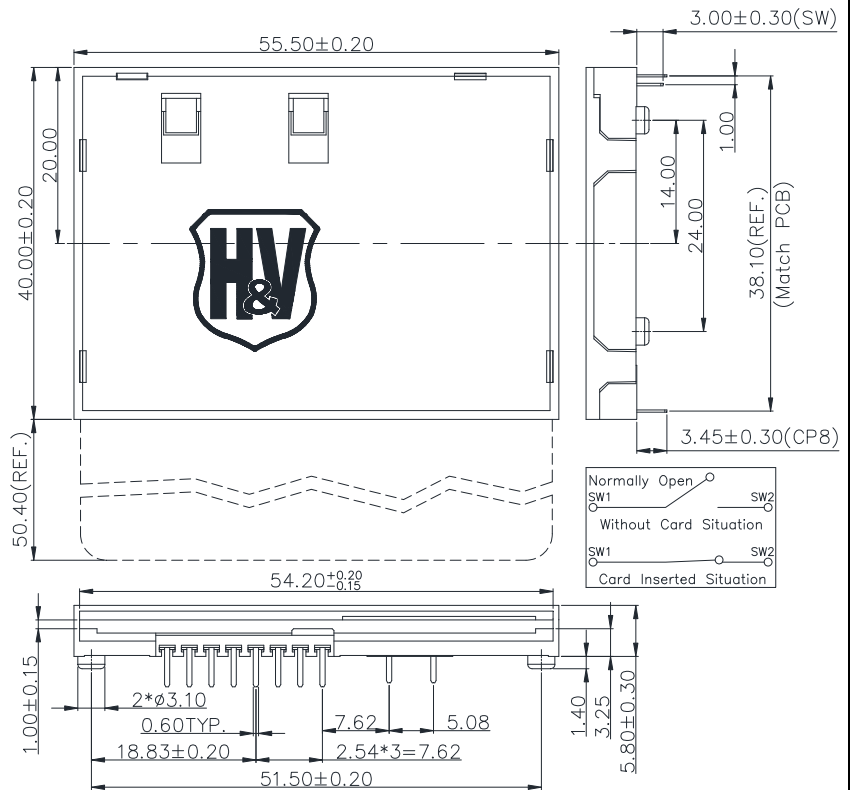

Unit: mm; Tolerances: ±0.15 mm
Mechanical outline dimension

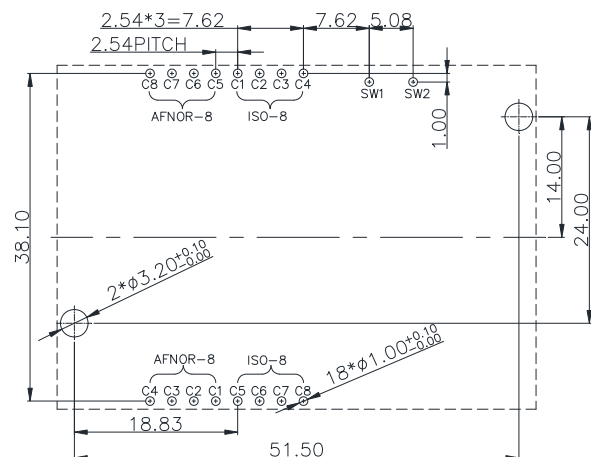

Unit: mm; Tolerances: ±0.05 mm
Reference dimension for PCB layout

H&V Smart Card Acceptor

Model No.: ICA-700 Type1 DIP 16Pin

Revision: 2.2

Date: MAY 01, 2014

For further information, please contact:

Tel: +886 2 2662 8882(Rep.) Fax: +886 2 2662 7201~2 E-mail: taipei@hamburg.com.tw URL: <http://www.hamburg.com.tw>